

# LINAX

www.linax.co.jp 株式会社 **ライナックス**



## Dust Collector

Specially designed, simple structured vacuums with stable and powerful suction performance.

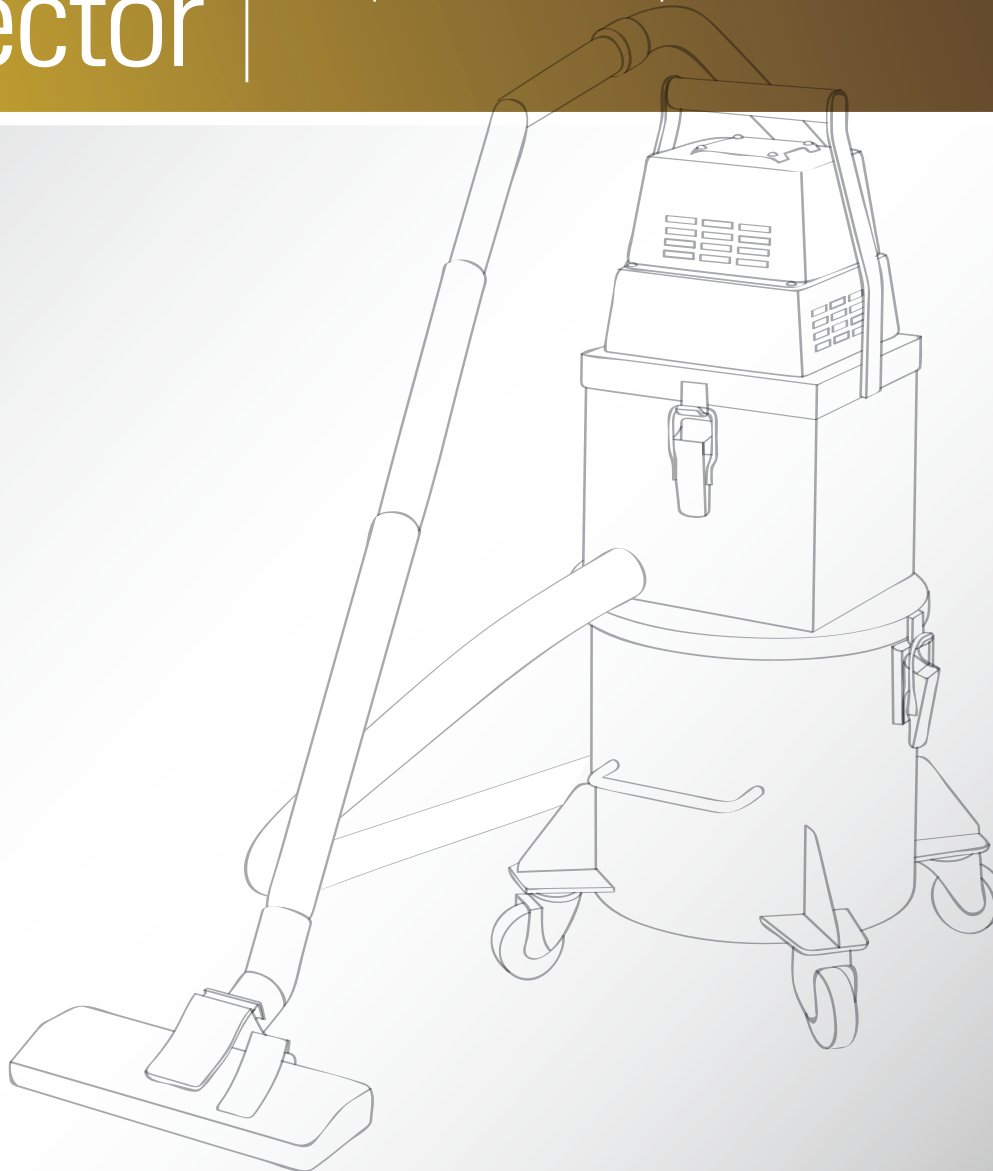

# Dust Collector series

- Anti-clogging Filtration
- User-friendly Features
- Easy to Clean Design

The Original Industrial dust collector series provides the best performing dust control solutions for any jobsite.

Dust Collection system to fit any handy tool, Floor Grinder, Scarifier, Grooving Machine, etc.

Easy handling and transportation, high durability and efficiency, and a long service life.



	L-1 Compact Type		V-1 Single-head Type		V-2 Dual-head Type	
Power (V)	220	240	220	240	220	240
L x W x H (mm)	386 x 319 x 540		360 x 360 x 790		456 x 534 x 831	
Total Weight (kg)	14.5		20.5		37.5	
Max. Wind Power (m <sup>3</sup> /min)	2.6	2.7	2.6	2.7	5.2	5.4
Max. Static Pressure (kPa)	22.6	21.6	22.6	21.6	22.6	21.6
Filter Area (m <sup>2</sup> )	0.64		0.64		2.0	
Output (W)	1,010		1,010		2,000	
Dust Tank Capacity (L)	19		18		38.5	
Power Cable	10 m (1.25 mm <sup>2</sup> x 3-core)		10 m (1.25 mm <sup>2</sup> x 3-core)		20 m (2.0 mm <sup>2</sup> x 3-core)	



## Compact Type

### Standard Accessories

- Suction Hose (38 mm x 2.5 m) w/handle
- Telescopic Tube
- Floor Nozzle
- 2 Dust Bags



Handy, robust and portable. Easy mobility in congested jobsites



Works with a combination of handy grinders



Anti-clogging filtration system with easy manual filter cleaning

## Features

- Compact and Lightweight
- Equipped with a Powerful 1kW Motor
- Versatile Solution for Building Sites and Crowded Areas



Faster and easier dust dumping



Faster and easier dust dumping



Anti-clogging filtration system with easy manual filter cleaning

## Single-head Type

### Standard Accessories

- Suction Hose (38 mm x 2.5 m) w/handle
- Telescopic Tube
- Floor Nozzle
- 2 Dust Bags



Catch clip system for easy filter replacement



Works with a combination of handheld tools and compact walk-behind grinders



# V-2

## Dual-head Type

### Standard Accessories

- Suction Hose (38 mm x 3.3 m)
- Straight Tube
- Bent Tube
- Floor Nozzle



### Optional Accessories

- Floor Sweeping Kit:  
Floor Nozzle, Bracket & Hose



## Features

- Heavy-duty type dust collector with a robust design
- Versatile usage on variable jobsites
- Catch clip system for easy filter cleaning and replacement

The operator can easily control both the main equipment and the dust collector without assistance.



Save Time, Saves Costs, Save Energy !



Anti-clogging filtration system with easy manual filter cleaning



Lockable swivel caster



## Different Styles of Usage

### General Cleaning Setting



### Floor Sweeping Setting



Install a floor nozzle bracket (option) for the "Floor Sweeping Setting" which helps to collect dust easily.

### Combination Setting



This picture shows the dust collector combined with a floor scarifier.



Combinable with a grinder or scarifier to perform dustless operations. Easy handling by one person without any assistance.



# Dust Collector



株式会社 **ライナックス**

本社 〒359-0027  
埼玉県所沢市松郷151-6

☎ 04-2946 5211    🌐 www.linax.co.jp  
☎ 04-2946 5212    ✉ linax@linax.net

**LINAX CO., LTD.**

Head Office: 151-6 Matsugo, Tokorozawa-shi,  
Saitama-ken, 359-0027 Japan

☎ 81-4-2946 5211    🌐 www.linax.co.jp  
☎ 81-4-2946 5212    ✉ linax@linax.net

